

空心杯电枢绕组

Φ28*L54mm无刷电机Brushless DC motor

SINBAD EC motor

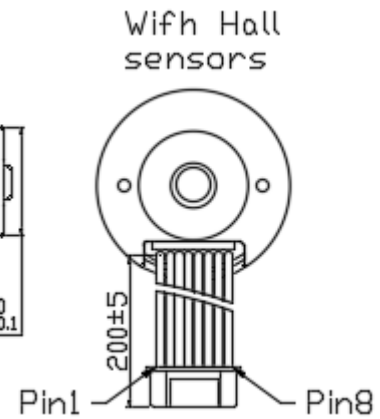
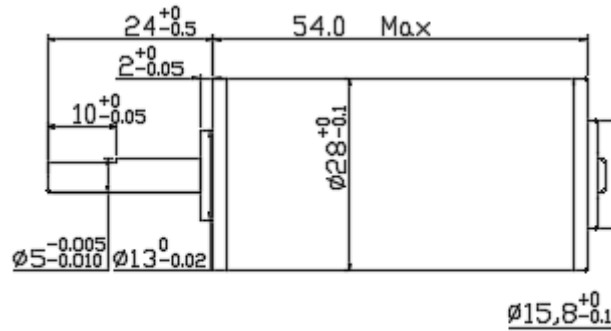
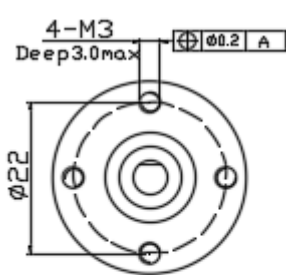

电机参数 Motor Datas			电机型号 Motor Model			
额定电压参数值 Value at rated voltage			XBD2854H2			
			4039WG-05240			
额定点 Nominal	1	额定电压 Rat voltage	V/DC	24		
	2	额定转速 Nominal speed	rpm	3397		
	3	额定电流 Nominal current	A	0.4		
	4	额定转矩 Nominal torque	mNm	15.94		
空载点 Free Load	5	空载转速 No load speed	rpm	3997		
	6	空载电流 No load current	mA	75.0		
最大效率点 At Max. Efficiency	7	最大效率 Max. efficiency	%	65.0		
	8	转速 Speed	rpm	3357		
	9	电流 Current	A	0.4		
	10	转矩 Torque	mNm	16.998		
最大输出功率点 At Max. Output	11	最大功率 Max. output	W	11.1		
	12	转速 Speed	rpm	1998.5		
	13	电流 Current	A	1.0		
	14	转矩 Torque	mNm	53.12		
堵转点 At Stall	15	堵转电流 Stall current	A	2.0		
	16	堵转转矩 Stall torque	mNm	106.24		
电机常数 Motor Constants						
	17	电机阻抗 Terminal resistance	Ω	12.00		
	18	电机感抗 Terminal inductance	mH	2.15		
	19	转矩常数 Torque constant	mNm/A	55.19		
	20	转速常数 Speed constant	rpm/V	166.5		
	21	转数/转矩常数 Speed/torque gradient	rpm/mNm	37.6		
	22	机械时间常数 Mechanical time constant	ms	1.6		
	23	转子惯量 Rotor inertia	gcm ²	3.6		
电机特性曲线 (Motor Characteristics)						
	24	极对数 Number of pole pairs	1			
	25	相数 Number of phasses	3			
	26	重量 Weight of motor	g	180		
	27	噪音 Typical noise level	dB	≤45		

电机端子定义 Motor terminal definition		
Black	√ V hall+5 VDC	Pin1
Black	√ Hall sensor A	Pin2
Black	√ Hall sensor B	Pin3
Black	√ Hall sensor C	Pin4
Black	√ GND	Pin5
Black	√ Motor winding A	Pin6
Black	√ Motor winding B	Pin7
Black	√ Motor winding C	Pin8

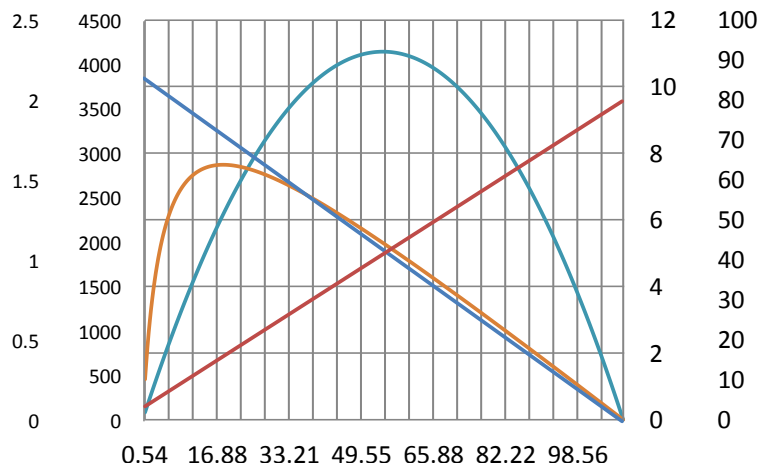

Connection : JST-PAP-08V-S

防护等级 Protection grade IP 54 A rpm mN.m W %

